

## THE MANAGEMENT AND EXCHANGE OF KNOWLEDGE AND INNOVATION IN ENVIRONMENTS OF COLLABORATING SMALL AND MEDIUM SIZED ENTERPRISES

P.H. OSANNA \*), N.M. DURAKBASA \*), L. CRISAN \*\*), J. M. BAUER \*\*\*)

\*) Vienna University of Technology - TU-Wien - Vienna, Austria

\*\*) Technical University Cluj-Napoca, Cluj-Napoca, Romania

\*\*\*) National University of Lomas Zamora - Buenos Aires, Argentina

### Abstract

*The importance of small and medium sized enterprises (SMEs) is today far beyond any discussion in countries all over the world - in European countries as well as in Asia and in USA, in Africa as well as in Latin America. To meet market demands in present and future global industrial world, manufacturing enterprises of any kind and any size must be flexible and agile enough to respond quickly to product demand changes. With support of artificial intelligence and modern information technology it is possible to realise modern cost-effective customer-driven design and manufacturing taking into account the importance and basic role of quality management and metrology. This will be especially possible on the basis of the innovative concept and model for modern enterprises the so-called "Multi-Functions Integrated Factory - MFIF" that makes possible an agile and optimal industrial production in any kind of industry and especially in up-to-date SMEs.*

**Key words:** *Quality engineering, quality management, TQM, metrology, small and medium sized enterprise SME, information technology, artificial intelligence*

### 1. The Global Importance of SMEs

To meet high-level demands both from industrial and from private customers in the future, manufacturing enterprises must be flexible and agile enough to respond quickly to product demand changes. New models for alternative configurations of future industrial organisations in general which are usually applied and especially for small and medium sized enterprises (SMEs) need to be investigated.

Those new models can be developed on the basis of intelligent production technologies and extensive use of the internet, of distributed computing environment (DCE) technology, parallel-processing computing and advanced engineering data exchange techniques [1]. By these means global competitive

associations of factories as well as of collaborating SMEs with intelligent, associative, concurrent, interactive, modular, integrative, learning, autonomous, self optimising and self organising functions are already under development and the world wide application of such associations and cooperations will be possible in the near future.

### 2. Cooperation and Collaboration of Modern Industrial Plants

Multi-Functions Integrated Factory MFIF is an innovative concept and model for future enterprises and collaborations which is initiated with the aim to provide cost-effective, agile and optimal ways to produce customer-driven Multi-Functional Products MFPs in the near future (see Figure 1). By means of information technology and artificial intelligence, factories which for instance produce cars, aircrafts and ships respectively could be linked to form a new kind of collaboration with all three functions according to needs. The product - MFP - will be produced in such a way that the above mentioned different function tasks of the product should be manufactured in adequate function factory or function SME, and then assembled and integrated to realize the combination of the functions. The collaboration works by using its advantages of multi-functions, and produces high efficiently and agilely low cost high quality customer-driven multi-functional products [2].

Such MFIF or SME collaboration has the potential to improve industrial competitiveness. Additionally comprehensive manufacturing automation and optimal production of customer-driven MFPs will be made possible worldwide. Intelligent manufacturing systems (IMS) are the basis for realization of such a collaboration in which individual functional enterprises or functional SMEs are functionally and configurationally integrated with other functional units located in different parts of the world to produce MFPs respectively. This new concept of SME

collaborations or MFIFs will come into existence in the near future and will be realised step by step. One of its specific features is the use of cross-functional design and manufacturing teams, in which the small engineering teams or single engineers of the units or SMEs with different skills and expertise work together on a MFP project concurrently and interactively.

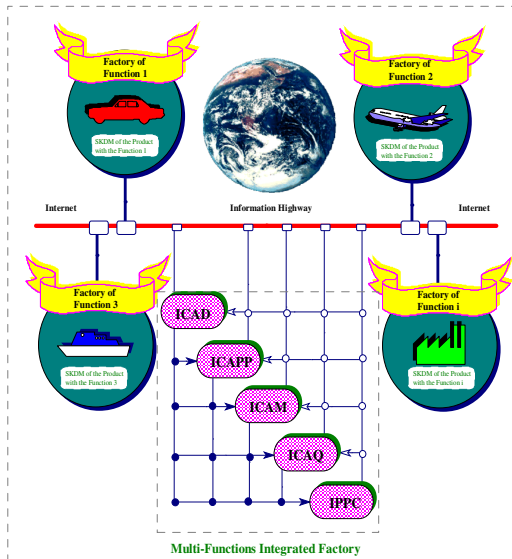

**Figure 1.** Integration of Intelligent Computer Aided Quality Control (ICAQ) and Intelligent Computer Aided Metrology (ICAM) into the Model of MFIF and SME Collaboration respectively

Such a system is based on the assumption that it works under the condition that each single-functional factory or SME has a possible full-scale IMS working environment

and is an integration of intelligent manufacturing machines, cells and systems for manufacturing and other tasks to be carried out. Concurrent, interactive, modular, integrative, learning, autonomous, self optimising and self organising functions are the main features of the MFIF or SME cooperation respectively.

The factories are reconfigurable to take advantages of agile manufacturing production for the MFPs. The system provides a function-business-shared feature to create new customer-driven markets. It is controlled and arranged by collaborative activities between the individual factories or SMEs. Cooperative activities between all units of the system can also be concurrently on-line carried out. Learning is carried out step by step by using the methods of evolution, and is used to optimise process control. It is possible that all the systematisation knowledges for design and manufacturing (SKDM) of each module of the system and all production information between ICAX systems of MFIF can be exchanged simultaneously on-line.

Failurefree concurrent exchange of production information and data, concurrent processing and

executing of production processes through distributed computing environment DCE and learning of all collaborative production processes are also features in global systems as there are MFIF or SME collaborations.

### 3. Quality Management and Metrology for Design and Production

#### 3.1. The Support of Artificial Intelligence

The quality assurance process will be carried out simultaneously in all product realisation steps in future factories - from the design process to the assembly procedures. In order to realise automatic quality assurance and to deal with complex, variable and dynamic quality control problems of the production processes in this environment, the quality assurance system will be enhanced comprehensively through self-optimising processes thrust in the design system and all manufacturing production processes of this environment. Quality management and quality assurance with intelligent, associative, concurrent, interactive, modular, integrative, learning, autonomous, self optimising and self organising functions will be realized especially in such environments of SME collaborations.

The assembly process is the final manufacturing step for MFPs in such an environment. This process will be carried out in one of the individual SMEs or factories which is near to the customers if possible. The coupling areas of the different function parts of MFPs are produced for ease-assembling, and they can be very easily combined and put together. By carrying out quality management and quality assurance activities in all manufacturing steps - from design to assembly - it will not be necessary to arrange final checks and quality assurance for completed MFPs or only few and very short such activities.

The way to scrap free and zero defect production will be made possible by learning with self improving ability, a goal which at least can be realised partly. Improvement and optimization of production processes is possible based on the supervision of quality in the process chain as well as by means of knowledge and learning management systems and self-learning systems. This method permits to learn stepwise from deviations and to improve the used processes continuously.

In the ICAQ system Fuzzy Logic will be applied for Quality Function Deployment (QFD) and for monitoring and forecasting of maintenance of measuring instruments [3], furtheron for CAD and for an expert system for tolerancing and quality planning.

In order to carry out concurrent, interactive and associative quality management and quality assurance and to optimise the quality assurance process through itself, learning methods for quality assurance processes must be used, and the ICAQ components of the factories or the cooperating SMEs link all process steps to each other from the design model to all other systems, so the quality management and quality assurance information for production of MFPs are automatically regenerated

when the design is changed or quality assurance activities are modified in one of the processes for MFP production.

### 3.2. Linking of Quality Management to Intelligent Design and Production

In MFIF, the design tasks of MFP can be carried out intelligently, interactively and concurrently. The exchange quality data and quality assurance data of the design work of MFP can be guaranteed by using the following technologies. Distributed design systems can be used for multi-functional product design and quality assurance for the design. Using DCE and parallel-processing technologies, the engineers and experts can work on parts of a design task, but the content of the design as a whole is a corporate resource to be managed and secured. This system makes it possible that the product designers of different function SMEs or factories can work parallelly on all the subtasks of the product.

Collaborative working method in MFIF has the goal to realise not only electronic data exchange function but also an interactive working function on-line, and to work at the different places and at heterogeneous systems out the same product model. Transmission of words, figures and sound by means of multimedia will also be integrated in such interactive CAD systems which could recognise manual drawings, learn the design process of the product, even understand the natural language instruction for the design, and optimise the design process and design quality. This kind of process would be guaranteed by modern data communication technologies and intelligent quality management and quality assurance as described above. The design quality and quality assurance data exchange of the design work of MFP can be guaranteed by using the already mentioned techniques.

An effective use of analysis, simulation and visualisation tools gives several advantages for MFP design and quality assurance of the design. In this system the designers from the different single-functional enterprises use typically parallel-processing, virtual reality and virtual prototyping technologies, to design and simulate the customer-driven MPFs and their systematical function activities as well as to create a fully digital MFP production and programs for the entire manufacturing process.

In the ICAM system, the quality management and quality assurance information and programs will also be on-line exchanged and modified concurrently, interactively and collaboratively. It runs autonomously according to the adequate functional quality assurance tasks and organises all manufacturing quality activities and units optimally in adequate factories. Learning the processes from the processes, the quality assurance parts of the ICAM units improve the all manufacturing process quality assurance parameters continuously.

The implementation of all these properties in an intelligent quality management and quality assurance architecture is a great challenge, and distributed, decentralised, self-

organised and self-optimised concepts will be the main approach for this goal.

## 4. Metrology and Quality Management in Global Factories

### 4.1. Intelligent Metrology and Intelligent Quality Assurance

In the already described computer-integrated and intelligent manufacturing environment, the integrated ICAQ system with intelligent coordinate metrology ICM is utilised to test the product or to scan and digitise complex product models with freeform surfaces. This is in order to obtain the digital model of the product and to modify it in ICAD system and then to create a new modified surface model and CNC programs for manufacturing of the final product by machine center in the workshop.

Intelligent coordinate metrology is a very important tool to solve various problems of quality management and quality assurance in MFP production especially when high flexibility and high accuracy are demanded simultaneously. This way of metrology is the up-to-date measuring method for complex dimensional and geometrical measuring problems.

The following Figures 2 and 3 illustrate a non-conventional application of intelligent coordinate metrology to support the improvement and optimisation of musical instruments. This is a typical task for metrology and manufacturing in a small producing enterprise. Figure 2 illustrates the schematics of the mouth piece of a clarinet whereas Figure 3 shows the measurement and evaluation of such a mouth piece. The correct sound of the instrument depends of the numerically defined exact form of both the side ribs and the tip rib of the mouth piece.

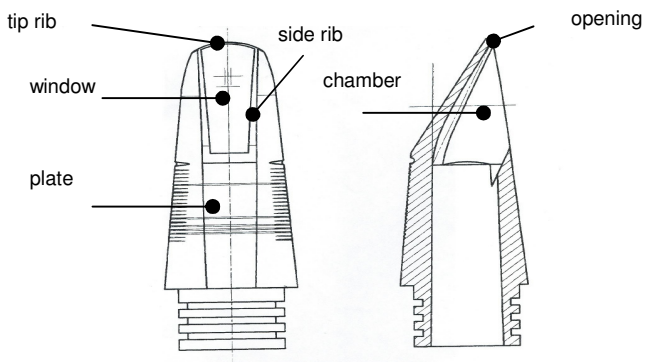
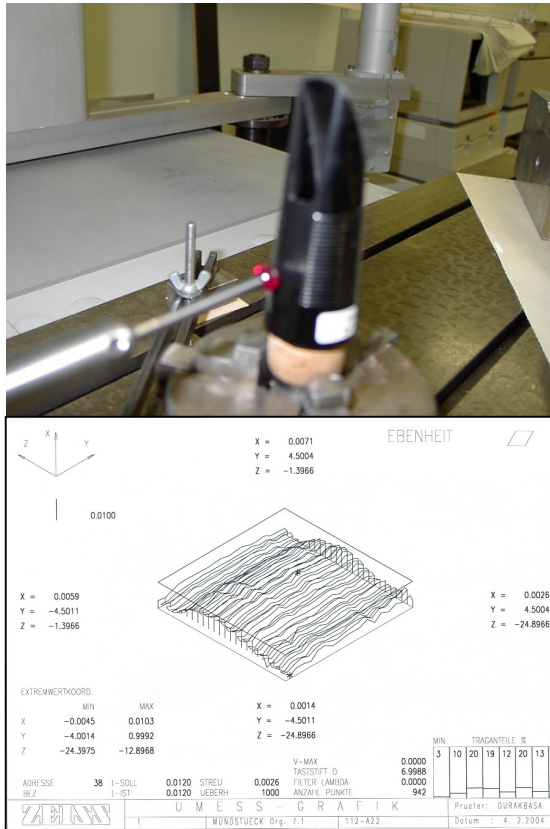

Figure 2. Mouth piece of a clarinet, schematic view

In a system or compound of SMEs as described above, CNC-controlled intelligent CMMs are connected by using networks with design and manufacturing. The goal is to mutually use the data stored in ICAD, ICAM and ICAQ systems, and to

realise data parallel-processing. For the concurrent production and the quality management system, it is suitable to use off-line programming technique, through which CNC inspection programs can be worked out without using the CMMs and the products. By means of this technique, the quality assurance data and inspection CNC programs can be generated simultaneously during the product design.



**Figure 3.** Measurement and evaluation of the mouth piece of a clarinet

Because of world wide needs for customer-driven MFPs, a global concurrent quality assurance system must be used with the support of internet and parallel processing computer technology. Internet makes it possible to establish a global quality assurance information highway for simultaneous on-line MFP quality assurance data exchange in global environment of collaborating SMEs or MFIF, and to interact with suppliers and customers world wide. Off-line programming for ICMM in ICAD system and in special programming software is the basis for simultaneous quality assurance in the individual enterprises but also in global MFIF. Many off-line programming packages as well as ICAD/ICAM/ICAQ system architecture are typical combinations in the integrated factory. ICAD/ICAQ data communication technique will be

widely used in MFIF. On the basis of computer aided measurement technique and especially coordinate metrology quality management is integrated in the production information network. Off-line programming packages based on 3D-CAD model that represents nominal data of products can be used for the application. The probe configurations can be selected through the created probe database. The operator can call all regular element measuring functions and the actual data evaluation functions, using main dialog menu of the package. On this basis measuring programs and the probe paths can be simulated, edited and optimised. During the simulation a CNC measuring program is generated in a specific format. Additionally a collision control function is realised through simulating the measuring processes on the computer monitor.

#### 4.2. Application of Non-conventional Metrology

Besides coordinate metrology modern optoelectronic methods are important measurement tools in computer integrated production plants and also as basic tools for global quality management and quality assurance activities. Their efficient use and correct calibration are crucial requirements for quality management in this environment.

Presently exists the general development from micro technology to "nano technology". Nano technology describes new innovative manufacturing technologies, finishes, tolerances and especially measurement technique in the nanometer range [4, 5, 6].

In persecution of this aim since about 1982 new high resolution and high precision measuring devices have been developed, especially Scanning Tunnelling Microscopy (STM) [7] and Atomic Force or Scanning Probe Microscopy (AFM, SPM). For highest demands these methods make it possible to explore atomic structures and in general very accurate and small industrially produced parts and structures. With scanning tunnelling and scanning probe microscopes lateral resolutions down to 10 nm and in vertical direction down to atomic resolution are achieved.

As example the following Figure 4 shows the measurement data of the structure of a workpiece surface after precision turning. The following Figure 5 shows a part of the surface of a precision endo prosthesis for the femoral head of a human hip joint.

It is emphasised, that in this respect applications in micro electronics do not stand in the focal point. Rather instruments of mechanical engineering and

particularly precision engineering are addressed in the first hand. Extremely high accuracy demands deposit presently already at highly developed instruments for everyday use as there are VCRs or CD-players and in the sensor technique in automotive engineering and even in the home appliance if we think on one-hand mixing taps which demand ultra precision form tolerances.

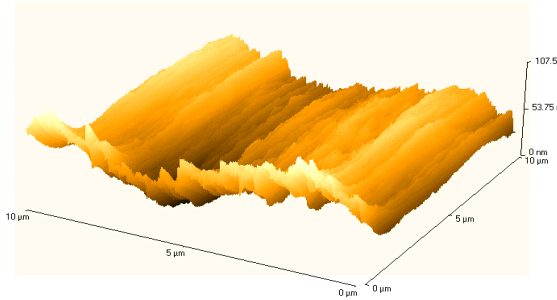

**Fig. 4.** Structure of Precision Machined Workpiece Surface

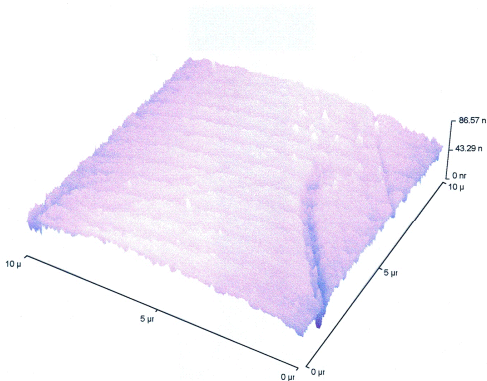

**Fig. 5.** Detail of the surface of a precision endo prosthesis for the femoral head of a human hip joint with a 40 nm deep scratch

**5. Proposal for an Intelligent Quality Assurance System**

For the intelligent flexible automation of quality management and quality assurance, data collection and evaluation in single functional enterprises a proposed system in the form of an intelligent measuring cell can solve the following tasks:

- automatic intelligent measurement by using CNC metrology,

- off-line CNC programming of measuring instruments,
- automatic changing of workpieces,
- automatic changing of probes and sensors,
- automated evaluation of measuring results.

Figure 6 shows the principal structure of such an Intelligent Quality Assurance Cell according to the above given definition. It consists of a series of devices and components:

- a local area network of various PCs especially for ICAD, ICAE and ICAQ evaluation,
- a precision intelligent CNC dimensional measuring instrument with control computer,
- a probe changer with interface and control computer,
- a robot for workpiece manipulation,
- various measuring instruments, for instance a small CMM and other devices,
- a scanning probe microscope to evaluate surfaces in the submicrometer and atomic range,
- printers for data and graphic output,
- database systems for construction data, measuring results and quality data etc.

The proposed solution can be seen as a further step with the goal to achieve intelligent and economical MFP manufacturing, inspection and quality management in MFIF, especially in small and medium sized multi-function integrated enterprises, and to find flexible solutions for all kinds of measurement problems in an automated intelligent manufacturing environment in MFIF.

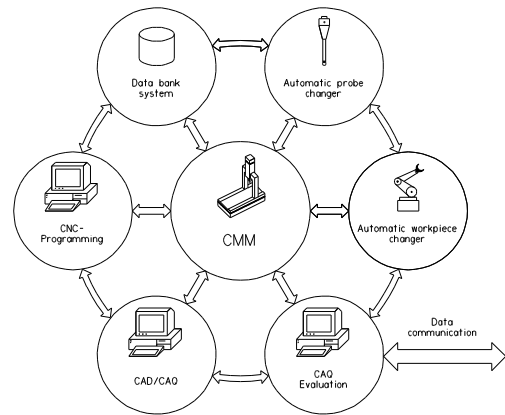

**Fig. 6.** Configuration of an Intelligent Quality Assurance Cell.

**6. Global Concurrent Quality Management**

The data communication model as already described in paragraph 2 is proposed as ideal future

solutions in global and intelligent manufacturing environment. By means of a common data model and powerful communication network established among ICAD/ICAQ and all other manufacturing processes, it is possible to realise the concurrent quality management and quality assurance activities and other production activities in modern manufacturing environment and especially in a global international cooperation of collaborating SMEs., e.g. all production processes, for example design and development, process planning, manufacturing, quality assurance and quality management etc., which are traditionally carried out sequentially, can be carried out parallelly in such a system. The quality management and assurance production knowledge can be stepwise parallelly established and refined. If a modified quality activity is made in a process, a correspondent quality assurance activity change will be simultaneously carried out in all other intelligent CAx systems.

The establishment of a global information highway for simultaneous on-line exchange of production data for collaboration on the design, quality assurance and all production processes, for concurrent communication of all the systematization knowledges for design, manufacturing and quality assurance of global and intelligent production, and to interact with suppliers and customers worldwide will be made possible. In [8] an example is described for an appropriate internet based application of production metrology and ICAQ. Basic studies for that system have been carried out in the course of an international University collaboration [9].

A global information system has to be investigated to fulfil the global information connection in MFIF environment. The development of information highway, DCE technology and advanced engineering data exchange technique make global information systems possible. Such systems can be realised by utilising the mentioned technologies, by means of which whole collaborative, interactive and concurrent design and manufacturing processes of products in global and intelligent production environment can be achieved. An unambiguous representation and an exchange mechanism for computer-interpretable product data throughout the whole life cycle of a product is provided, independent from any particular system.

Through global information connection a quality assurance process could be so carried out, that during the CAD modelling the quality assurance planning, modeling, programming and simulating processes which cooperate with the customers and suppliers could also be simultaneously carried out. The design, quality assurance planning and the

quality assurance programming can be carried out at one place and the quality assurance simulating, measuring and evaluating processes can concurrently be carried out at another place in the world.

## 7. Outlook to Future Developments

In this contribution global competitive associations of factories as well as of collaborating SMEs have been presented as an innovative concept and a new model for manufacturing enterprises developed to meet demands for cost-effective customer-driven design and production. This concept can be used with success to realize agile and optimal global international cooperations of collaborating SMEs. The quality assurance process will be used in all product production processes in such a system - from the design stage to the final assembly. Quality management and quality assurance in individual activities of different function enterprises - big factories as well as SMEs - in such a collaboration structure play a basic role to ensure the realisation of the concept, e.g. through the intelligent production systems based on quality management and quality assurance in the system to create, to realize and to present the features, such as, concurrent, interactive, modular, integrative, learning, autonomous, self optimising and self organising functions.

In this presentation, the intelligent quality assurance system in MFIF, an off-line programming technique for ICMM as basis for simultaneous quality assurance and an intelligent measuring cell for the flexible automation of quality assurance and quality management, data collection and data evaluation in multi-function integrated factory was proposed and discussed. Optoelectronic and Nanotopographic quality assurance methods and a global data communication model for the future that is investigated to realise the concurrent quality management and quality assurance activities and other production activities in MFIF, e.g. all production processes, for example design and development, process planning, manufacturing and quality assurance and management etc., which are traditionally carried out sequentially, can be parallelly carried out in MFIF in global and intelligent manufacturing environment, are introduced.

Quality management systems with intelligent, associative, concurrent, interactive, modular, integrative, learning, autonomous, self optimising and self organising functions will be realized in global international cooperations of collaborating small and medium sized enterprises in the near future.

## 8. References

- [1] Osanna, P.H., Si, L.: Multi-Functions Integrated Factory MFIF - a Model of the Future Enterprise. Conference Proceedings of "Internet Device Builder Conference", Sta. Clara, May 2000, 6pp.
- [2] Si, L., Osanna, P.H.: Multi-Functions Integrated Factory. Proceedings of 11th ISPE/IEEE/IFAC International Conference on CARS&FOF'95, Colombia, 1995, 578/586.
- [3] Durakbasa, N.M., Osanna, P.H.: The Role of Co-ordinate Metrology in the Hierarchical Structure of Metrology and the System for Measurement Instruments Confirmation. Proceedings: 5th International Scientific Conference Coordinate Measuring Machines, Bielsko-Biala, PL, 2002, ISSN 0867-3128, 55/62.
- [4] Taniguchi, N.: On the Basic Concept of Nanotechnology. Proc. Int. Conf. Prod. Eng., Tokyo: JSPE, part 2, 1974, 18/23.
- [5] Whitehouse, D.J.: Nanotechnology Instrumentation. Measurement + Control, 24 (2), 1991, 37/46.
- [6] Whitehouse, D.J.: Surface and Nanometrology, Markov and Fractal Scale of Size Properties. Proceedings of 7th International Symposium on "Laser Metrology Applied to Science, Industry and Everyday Life - LM-2002", Nowosibirsk, Russia (Editors: Y.V. Chugui, S.N. Bagayev, A. Weckenmann, P.H. Osanna), © 2002 SPIE - The International Society for Optical Engineering, ISBN 0-8194-4686-6, 2002, 691/707.
- [7] Binnig, H., Rohrer, H.: Scanning Tunnelling Microscopy. Helv. Phys. Acta 55, 1982, 726/731.
- [8] Fu, S., Raja, J.: Internet Based Roundness and Cylindricity Analysis. IMEKO 2000 Proceedings, Vol. VIII, Editors: Durakbasa, M.N., Osanna, P.H., Afjeji-Sadat, A., Wien: Austauschbau und Messtechnik, ISBN 3-901888-10-1, 2000, 83/88.
- [9] Steindl, K.G.: Development of a Software Package for the Internet Based Analysis of Roundness Data. Master Thesis, TU-Wien, A, and UNC Charlotte, USA, 1999.

### Authors:

Professor Dr. Dr. mult. h.c. P. Herbert **OSANNA** \*)

Professor Dr.techn. Prof. h.c. Numan M. **DURAKBASA** \*)

Professor Dr.Eng. Liviu **CRISAN** \*\*)

Professor Dr.techn. Eng. Jorge M. **BAUER** \*\*\*)

\*) Interchangeable Manufacturing and Industrial Metrology (Austauschbau und Messtechnik), Institute of Production Engineering, Vienna

University of Technology (TU-Wien), Karlspl. 13/3113, A-1040 Vienna, Austria.

\*\*) Technical University Cluj-Napoca, Cluj-Napoca, Romania

\*\*\*) Faculty of Engineering, National University of Lomas Zamora, Buenos Aires, Argentina

Phone: +43 1 58801 31142, Fax: +43 1 58801 31196, E-mail: osanna@mail.ift.tuwien.ac.at

Copyright © 2009 by the International Business Information Management Association (IBIMA). All rights reserved. Authors retain copyright for their manuscripts and provide this journal with a publication permission agreement as a part of IBIMA copyright agreement. IBIMA may not necessarily agree with the content of the manuscript. The content and proofreading of this manuscript as well as and any errors are the sole responsibility of its author(s). No part or all of this work should be copied or reproduced in digital, hard, or any other format for commercial use without written permission. To purchase reprints of this article please e-mail: [admin@ibima.org](mailto:admin@ibima.org).